

DO NOT SCALE IF IN DOUBT ASK

REF	DWG. No.	DESCRIPTION	QTY	REMARKS
26	9907.0140	GLAND REDUCER M32/M25	7	
25		FLP IDENTIFICATION LABEL	1	
24		DRAIN PLUG WARNING LABEL	2	
23		COVER WARNING LABEL	2	
22	6818.2219	BLANKING PLUG M25	2	
21	9907.1125	CLAW WASHER	8	
20	0068.0077	HEX HD SCREW M12x25LG.	4	
19	0068.0120	SKT HD CAP SCREW M10x30LG.	12	
18	6468.0357	SKT HD CAP SCREW M12x20LG.	12	
17	0063.0272	M16 PLAIN WASHER	88	
16	0063.0146	M16 SPRING WASHER	88	
15	0068.0044	M16 FULL NUT	88	
14	0068.0523	HEX HD BOLT M16 x 90LG.	88	
13	9907.0186	STOPPING PLUG M25	1	
12	9907.0033	GLAND REDUCER M25/M20	3	
11	9907.0074	CABLE GLAND A2F M20	3	
10	9907.0069	CABLE GLAND A2F M25	7	
9	99007.0030	CABLE GLAND A2F M32	3	
8	9920.3400	1.5MVA 5 LIMB CORE & COILS	1	SUPPLIED
7	9920.3400	TOP FIXING BRACKET	4	BY BWS
6	3518.2016	BOLT SHROUD	88	
5	3523.1008	TAP CHANGE COVER PLATE	1	
4	3518.2022	BUSHING PLATE LV FLANGE	1	
3	3518.2021	BUSHING PLATE HV FLANGE	1	
2	3510.1014	TRANSFORMER LID	1	
1	3510.1011	TRANSFORMER TANK	1	

PARTS LIST

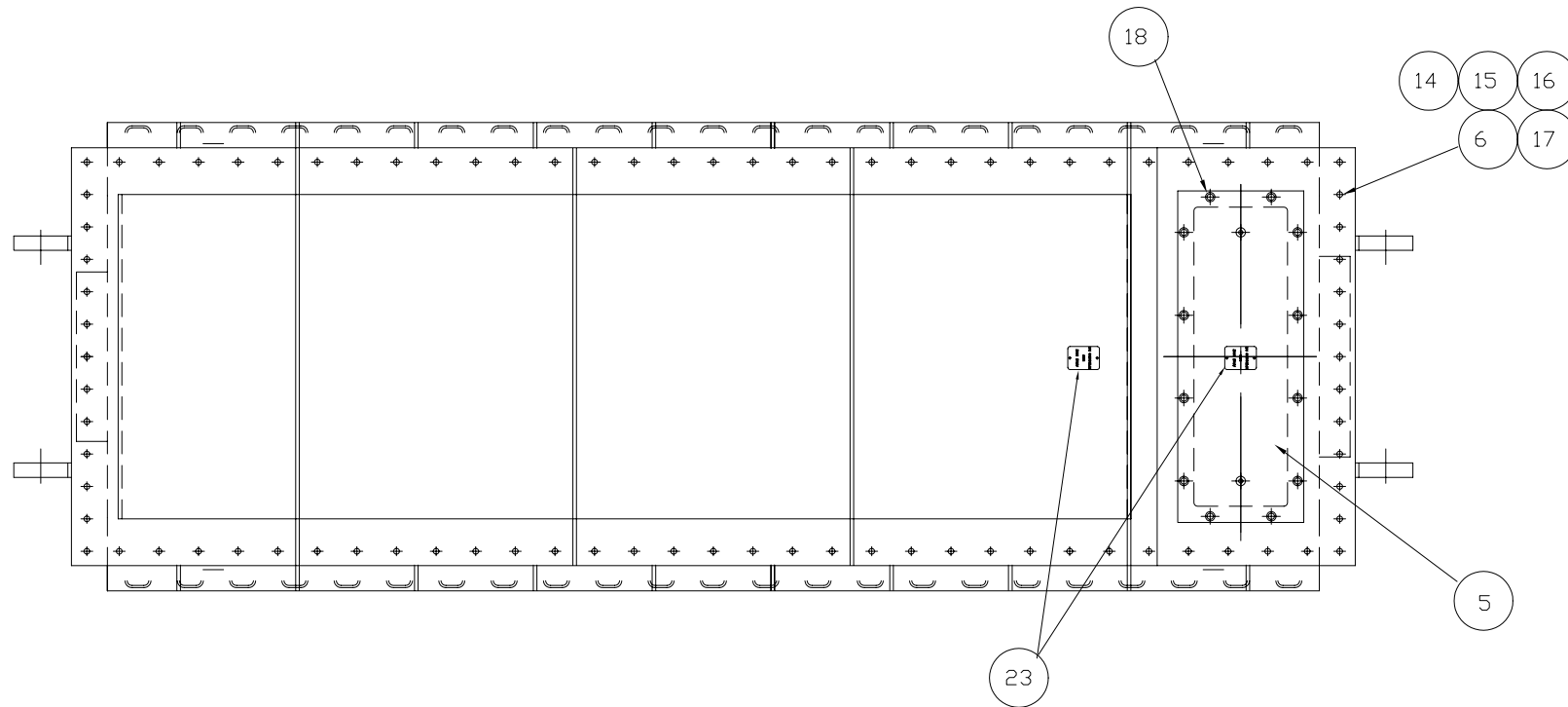

WEIGHTS:
CORE & COILS 6800kg
TANK 3800kg

© BALDWIN & FRANCIS LIMITED
All rights reserved. No part of this drawing may be reproduced in any material form (including photocopying or storing it in any medium by electronic means). Without the written permission of BALDWIN & FRANCIS LIMITED. Failure to comply with this notice may result in both a civil claim for damages and criminal prosecution.

THIRD ANGLE PROJECTION

DRG.No.
A1/3510.0002

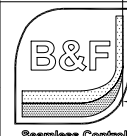
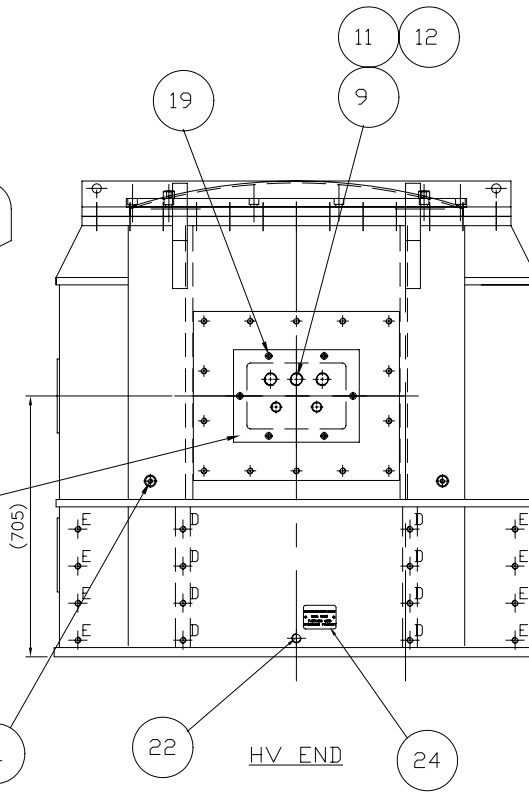
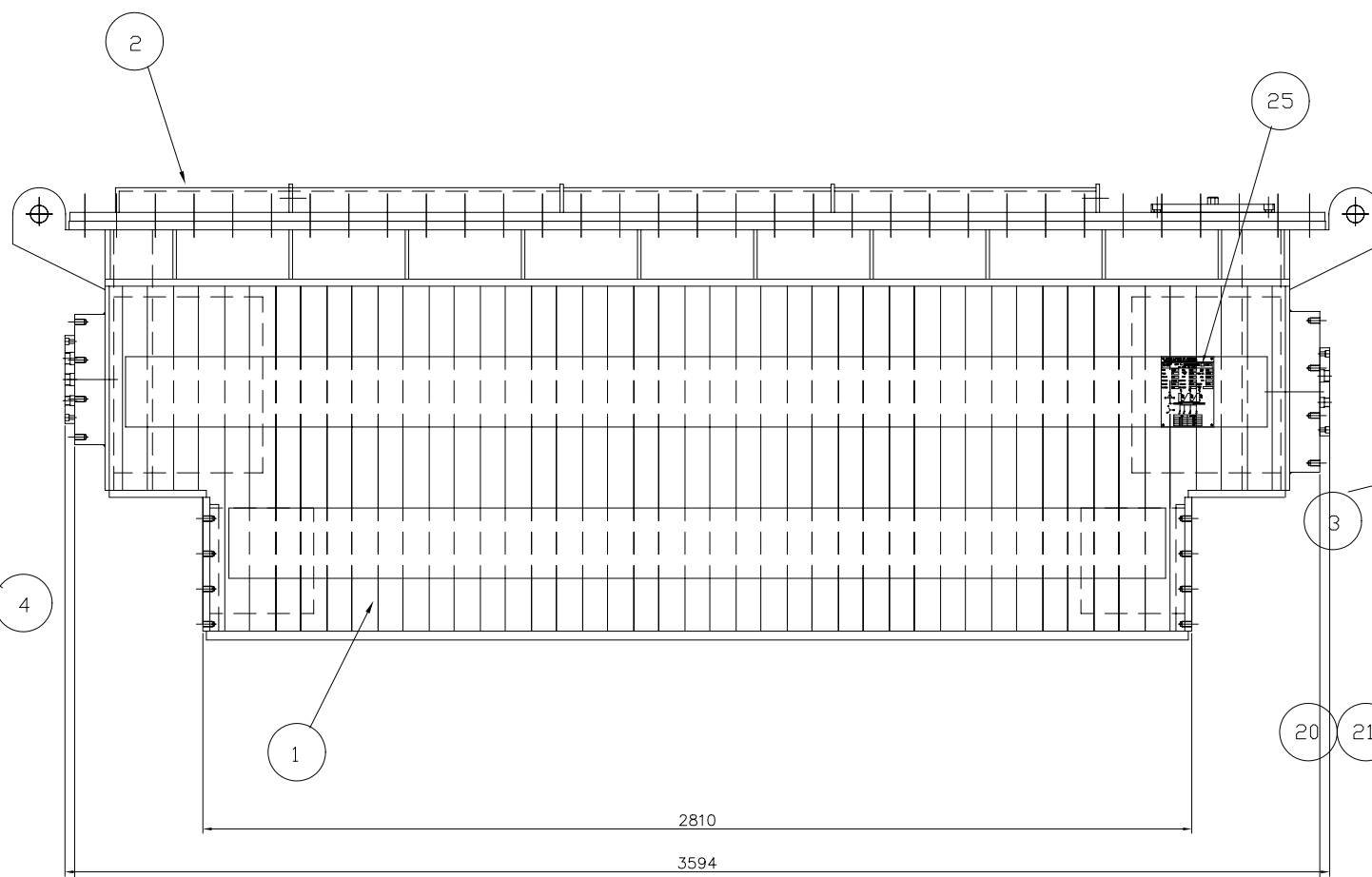
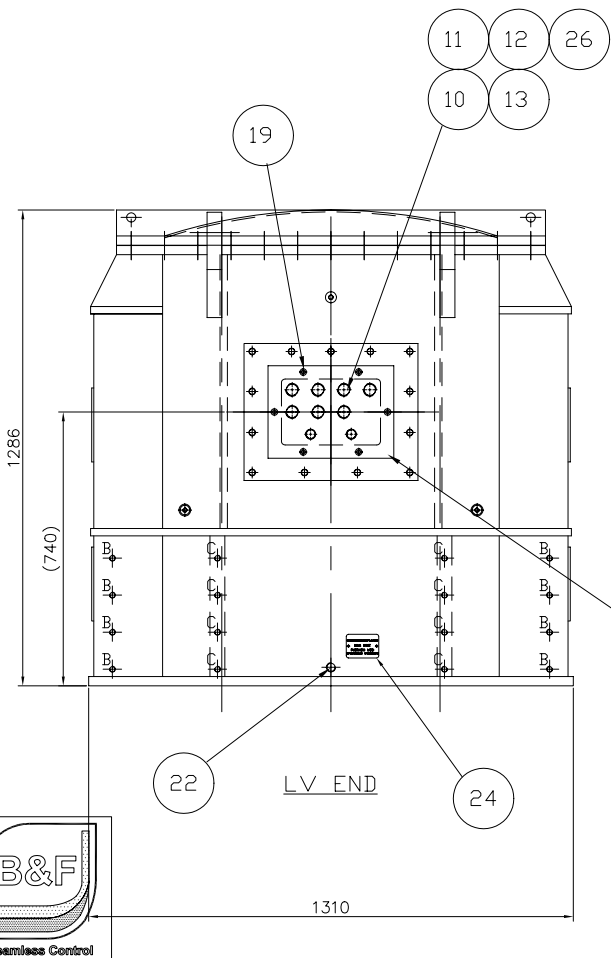

ALL DIMENSIONS IN MILLIMETRES UNLESS OTHERWISE STATED

TOLERANCES TO BE AS SPECIFIED BELOW UNLESS OTHERWISE STATED. (IMPERIAL DIMENSIONS IN BRACKETS).	
MACHINING	FABRICATION
UP TO 100mm ± 0.15mm	UP TO 300mm (12") ± 0.4mm
100 TO 300mm ± 0.4mm	300 TO 1000mm (36") ± 2mm (± 1/16")
300 TO 1000mm ± 0.8mm	1000 TO 2000mm (OVER 36") ± 3mm (± 1/8")
	CASTING
	WALL THICKNESS ± 12.5%

MACHINED SURFACE SYMBOLS			
SYMBOL	DESCRIPTION	THOU INCHES	MILLI-METRES
✓	DENOTES MACHINED BUT NOT GRADED	—	—
✓	DENOTES MACHINED & PROVED FLAT	3	0.07
✓	DENOTES MACHINED & PROVED FLAT	6	0.15
✓	DENOTES MACHINED & PROVED FLAT	8	0.20
✓	DENOTES MACHINED & PROVED FLAT	4	0.10
✓	DENOTES FACE TO BE GRIND	—	—

WELD SYMBOLS TO BS EN 24063 1992

FINISH SEE NOTE
TREATT
SCALE 1:10
REF

MATERIAL
MAKE FROM 3510.9002

TITLE 1.5MVA - 5 LIMB TRANSFORMER TANK MACHINING (MILD STEEL)

DRAWN AND CHECKED RH 18/3/13
DRAWING APPROVED

ABCDEFGHIJKLMNO

DRG.No. A1/3510.0002